

## TEMPERATURE SENSOR

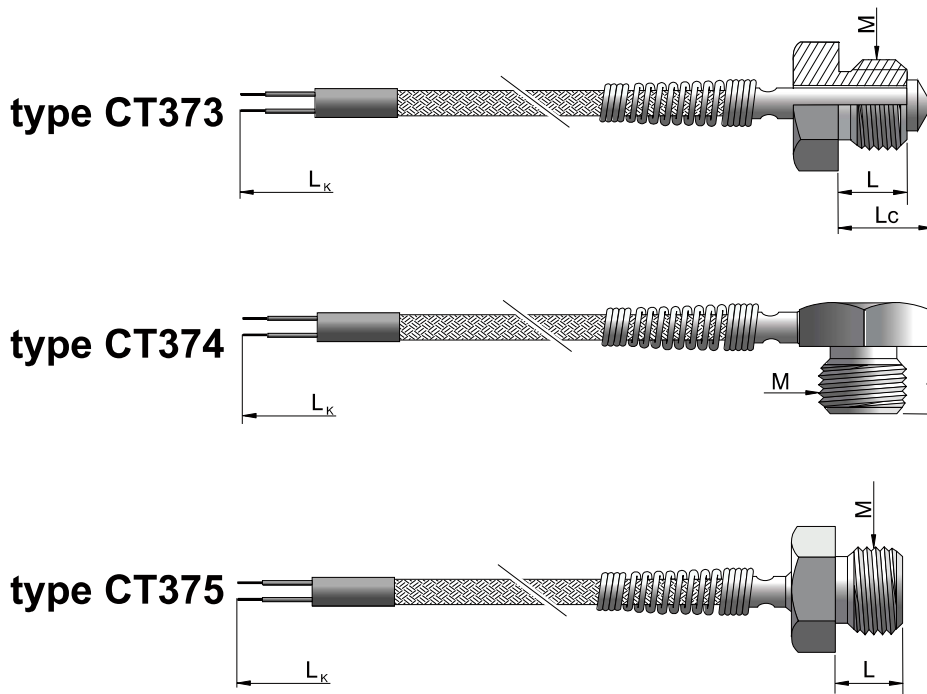

M <sup>(2)</sup>	L <sup>(2)</sup>	Lc <sup>(2)</sup>
M6	10	16,5
M8x1	12	19
M10x1	15	22,5
M12x1,5	20	29
M20x1,5	30	43
G1/2"	30	43
1/4"-20	15	21,5

### SPECIFICATION

Temperature range	-40°C...+400°C
Measuring element	platinum resistor <b>(Pt100)</b> <sup>(1)</sup> thermocouple Cu-CuNi <b>(T)</b> thermocouple Fe-CuNi <b>(J)</b> thermocouple NiCr-NiAl <b>(K)</b>
Class of processing element	2 <b>(B)</b> <sup>(2)</sup>
Measuring junction	insulated <sup>(2)</sup>
Sheath material	steel 1.4541
Cable insulation	fiber glass and steel braid <sup>(3)</sup>

<sup>(1)</sup> Pt500, Pt1000, Ni100, Ni1000 on demand

<sup>(2)</sup> Other parameters according to customer requirements

<sup>(3)</sup> Other cable insulation: PVC, silicon, PTFE, stainless steel armored sheath on demand

### ORDERING CODE

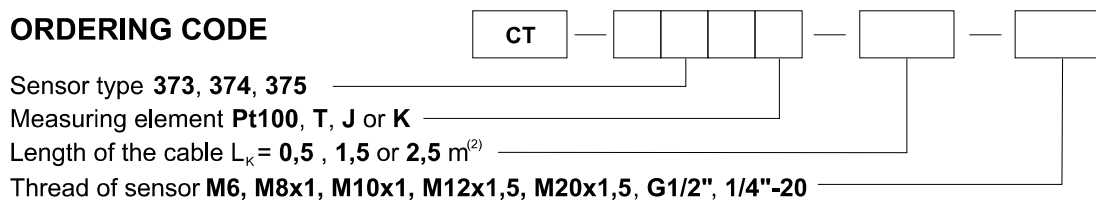

**Example for order** CT-375J-1,5-M10x1 thermocouple sensor Fe-CuNi (J), length L = 15 mm, length of the cable  $L_K = 1,5$  m with metric thread M10x1.