

DRAW WIRE SENSOR



Series MH120 for mobile hydraulics applications

Key-Features:

- Cost-effective sensor for construction machinery
- Measurement ranges from 3 to 10 m
- extreme robust construction
- Analog outputs: Potentiometer, 0...5 V, 0...10 V, 4...20 mA, optional redundant
- teachable outputs: 0...5 V, 0...10 V, with an additional Open-Collector switching output
- Digital output: CANopen, optional redundant
- Linearity up to ± 0.1 % of full scale
- Protection class up to IP69K (suitable for close-range high pressure, high temperature spray downs)
- Temperature range -20...+85 °C (optional -40 °C)

Content:

Introduction2
Technical data3
Analog outputs3
Digital output CANopen4
Electrical connection4
Technical drawing5
Options7
Accessory for teachable outputs8
General accessories8
Installation and warning notices9
Order code	..10

INTRODUCTION

The draw wire sensors of the mobile hydraulic series MH120 were specially developed for the demanding area of construction machines and construction equipment. The sensor can be individually configured depending on the application, in which it is used. Small adhesive and abrasive particles with small grain size can easily be removed when using the open MH120 versions. Seawater resistant protective grating provide a maximum protection against larger foreign objects like tree branches. In case of applications with high safety requirements, thicker stainless-steel wire ropes are available, as well as redundant, analogue outputs. This mobile hydraulics series offers the possibility the perform accurate and cost-effective distance measurement on construction machinery.

HOUSING VARIANTS

The MH120 series comprises four different types of housings.
Common to all versions:

- Aluminium housing with bore holes for the mounting
- easy rope fixation by rope clip, secured against twisting
- stainless steel wire rope
- Sensor element inside an enclosed housing
- M12 connector system or cable output
- dynamic spring drive with PA6 case

Standard: open housing + open rope bridge

Especially suited for applications under the conditions of fine dust and fluids.

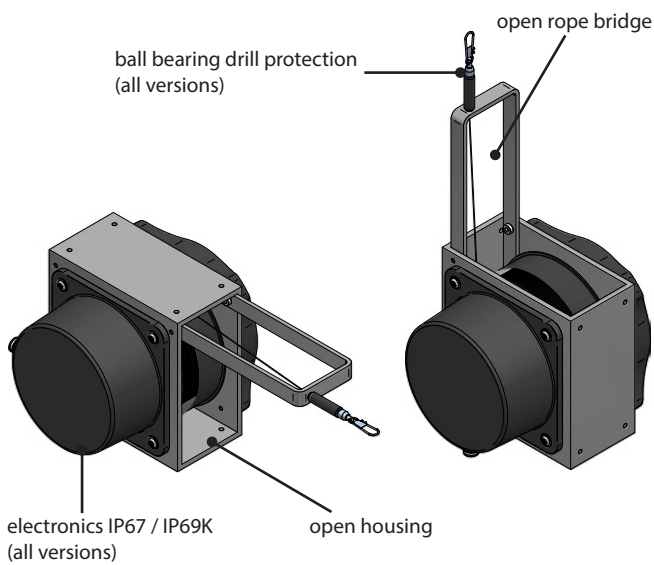

Version C1: housing with perforated plate covering + open rope bridge

Especially suited for applications under the conditions of dirt, particle size > 2 mm and fluids.

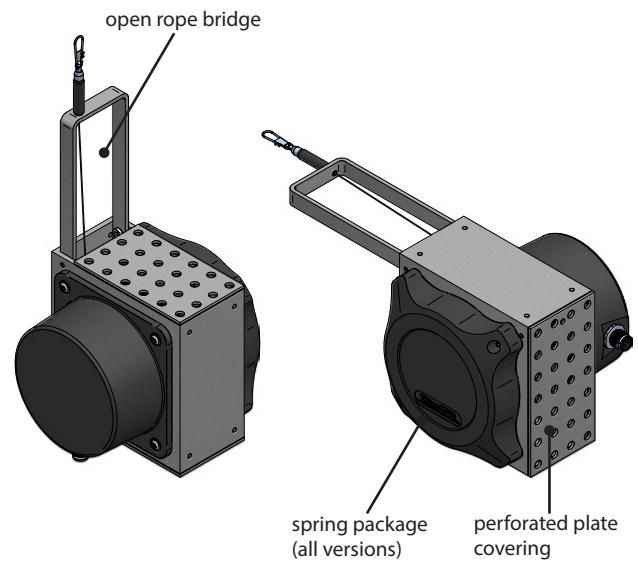

Version C2: housing with perforated plate covering + closed rope bridge

Especially suited for applications under the conditions of dirt, particle size > 2 mm and fluids, protection against impact and shock, rope cleaner (in preparation)

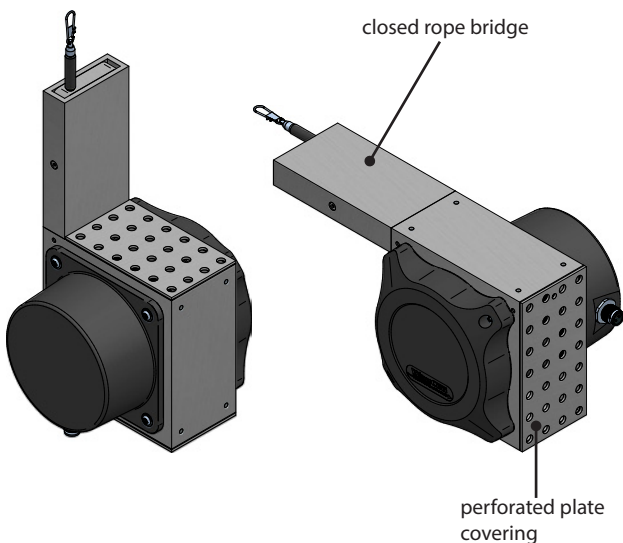

Version C3: closed housing + closed rope bridge

Especially suited for applications under the conditions of adhesive dust, cement, concrete, clay, protection against impact and shock, rope cleaner (in preparation)

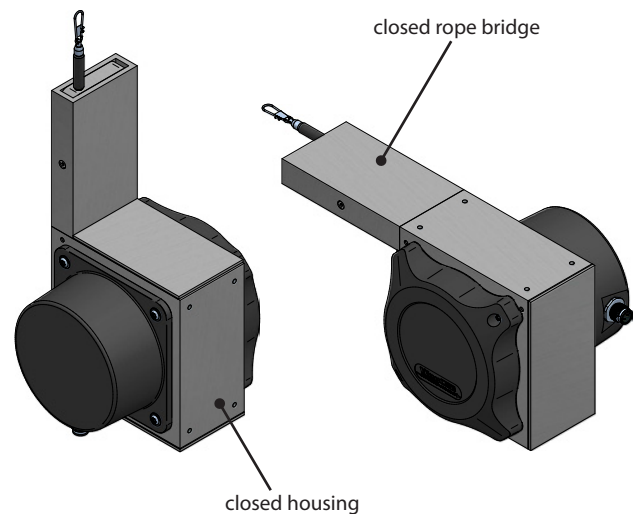

TECHNICAL DATA

Measurement range	[m]	3	4	5	6	7	8	9	10
Linearity	[%]	±0.5							
Improved linearity (optional)	[%]	±0.25 or ±0.1							
Rope diameter	[mm]	0.5 / 1 / 1.5			0.5 / 1			0.5	
Resolution		see output types							
Sensor element		potentiometer							
Output signals *		potentiometer, 0...5 V, 0...10 V, 0...5 V (teachable), 0...10 V (teachable), 4...20 mA, CANopen							
Redundant output signals		optional for: potentiometer, 0...5 V, 0...10 V, 4...20 mA, CANopen							
Connection		connector output M12 radial or cable output radial (TPE cable, standard length 2 m)							
Protection class		IP67, optional IP69K (only in combination with cable output)							
Humidity		max. 90 % relative, no condensation							
Temperature		see output types below							
Rope extraction speed	[m/s]	max. 3							
Acceleration	[m/s ²]	max. 50							
Weight	[g]	1300 up to 1600 (depending on the measurement range)							
Housing		Aluminium, spring case PA6							
Extraction force	[N]	$F_{\min} = 7 / F_{\max} = 13$ (depending on the measurement range)							

* other output signals on request

ANALOG OUTPUTS

	Potentiometer 1 kΩ	Voltage 0...5 V, 0...10 V	Current 4...20 mA	Voltage 0...5 V, 0...10 V (teachable up to 50 % MR)
Output	1 kΩ	0...5 V, 0...10 V, galvanically isolated, 4 conductors	4...20 mA, 2 conductors	0...5 V, 0...10 V, 3 conductors
Supply	max. 30 V	12...30 VDC		8...35 VDC
Recommended cursor current	< 1 μA	-		
Current consumption max.	-	22.5 mA (unloaded)	-	
Current consumption max.	-	-	-	150 mW
Output current	-	max. 10 mA, min. load 10 kΩ	max. 50 mA in case of error	max. 10 mA, min. load 1 kΩ
Dynamics	-	< 3 ms from 0...100 % and 100...0 %	< 1 ms from 0...100 % and 100...0 %	1 ms
Resolution	theoretically unlimited, limited by the noise			1 mV
Noise	dependent on the quality of the power supply	3 mV _{pp} typical, max. 37 mV _{pp}	0.03 mA _{pp} = 6 mV _{pp} at 200 Ω	3 mV _{pp} typical, max. 37 mV _{pp}
Inverse-polarity protection	-	yes, infinite		
Short-circuit proof	-	yes, permanent	-	yes, permanent
Working temperature	-20...+85 °C / optional: -40...+85 °C			
Temperature coefficient	± 0.0025 %/K	0.0037 %/K	0.0079 %/K	0.0016 %/K
Elektromagnetic compatibility (EMC)	-	according to EN 61326-1:2013		

Circuit

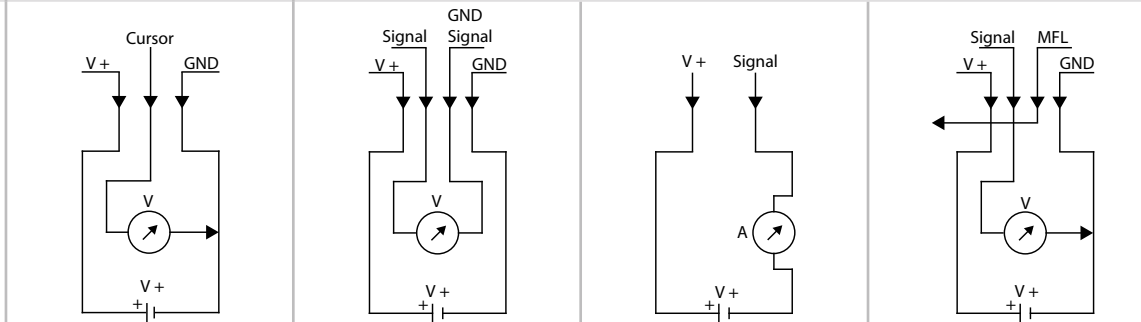

MFL = multi-functional line

DIGITAL OUTPUT CANopen

CAN specification		Full CAN 2.0B (ISO11898)
Communication profile		CANopen CiA 301 V 4.2.0
Device profile		Encoder, absolute linear; CIA 406 V 3.2.0
Error control		Producer Heartbeat, Emergency Message, Node Guarding
Node ID		Default: 7, configurable via SDO and Squeezer (offline configuration)*
PDO		1 x TPDO, static mapping
PDO Modes		Event-triggered, Time-triggered, Sync-cyclic, Sync-acyclic
Transmission rate		1 Mbps, 800, 500, 250, 125, 50, 20 kbps configurable via SDO and Squeezer (offline configuration)*
Bus connection		M12 connector, 5 pins
Integrated Bus termination resistor		120 Ω, connectible via SDO and Squeezer (offline configuration)*
Bus, galvanic separation		No
Supply	[VDC]	8...30
Current consumption		10 mA typical at 24 V, 20 mA typical at 12 V
Measurement rate		1 kHz with 16-bit resolution
Repeatability	[%]	±0.5, ±0.25 or ±0.1 (according to the selected linearity)
Resolution		0.002 % of measurement range
Electrical protection		inverse polarity protection
Working temperature	[°C]	Standard: -20...+85 / optional: -40...+85
Temperature coefficient	[%/K]	0.0014
EMV		DIN EN61326-1:2013, conformity with directive 2014/30/EU

* Offline configuration via Squeezer only in combination with M12 connector 8 pins.
For more information on the offline configuration please refer to the CANopen manual.

ELECTRICAL CONNECTION

Analog output

- axiale cable or axiale connector M12, 4 pins

Cable colour	PIN	0...5 V, 0...10 V	0...5 V, 0...10 V (teachbar)	4...20 mA	1 kΩ
BN	1	V +	V +	V +	V +
WH	2	Signal	Signal	n. c.	Cursor
BL	3	GND	GND	Signal	GND
BK	4	GND Signal	MFL*	n. c.	n. c.

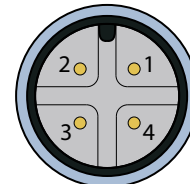

* multi-functional line

Redundant analog output

- axiale cable or axiale connector M12, 8 pins

Cable colour	PIN	0...5 V, 0...10 V	4...20 mA	1 kΩ
WH	1	V 1 +	V 1 +	V 1 +
BN	2	Signal 1	n. c.	Cursor 1
GN	3	GND 1	Signal 1	GND 1
YE	4	GND 1 Signal	n. c.	n. c.
GY	5	V 2 +	V 2 +	V 2 +
PK	6	Signal 2	n. c.	Cursor 2
BU	7	GND 2	Signal 2	GND 2
RD	8	GND 2 Signal	n. c.	n. c.



* multi-functional line

Cable specifications

	cable, 4 poles	cable, 8 poles
Cable type	TPE, flexible	
Direction	radial	
Length	2 m standard (other lengths on request)	
Diameter	Ø 4.5 mm	Ø 6.6 mm
Wire	0.14 mm ²	0.25 mm ²
Temperature	fixed installation -30...+85 °C, flexible installation -20...+85 °C	

For the assignment of the digital output CANopen (WCAN) please refer to the [manual](#).

TECHNICAL DRAWING

Standard: open housing + open rope bridge

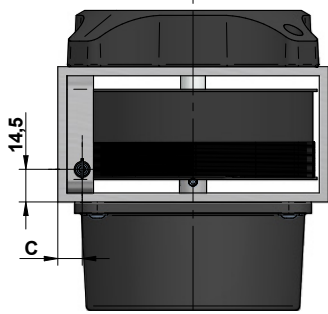
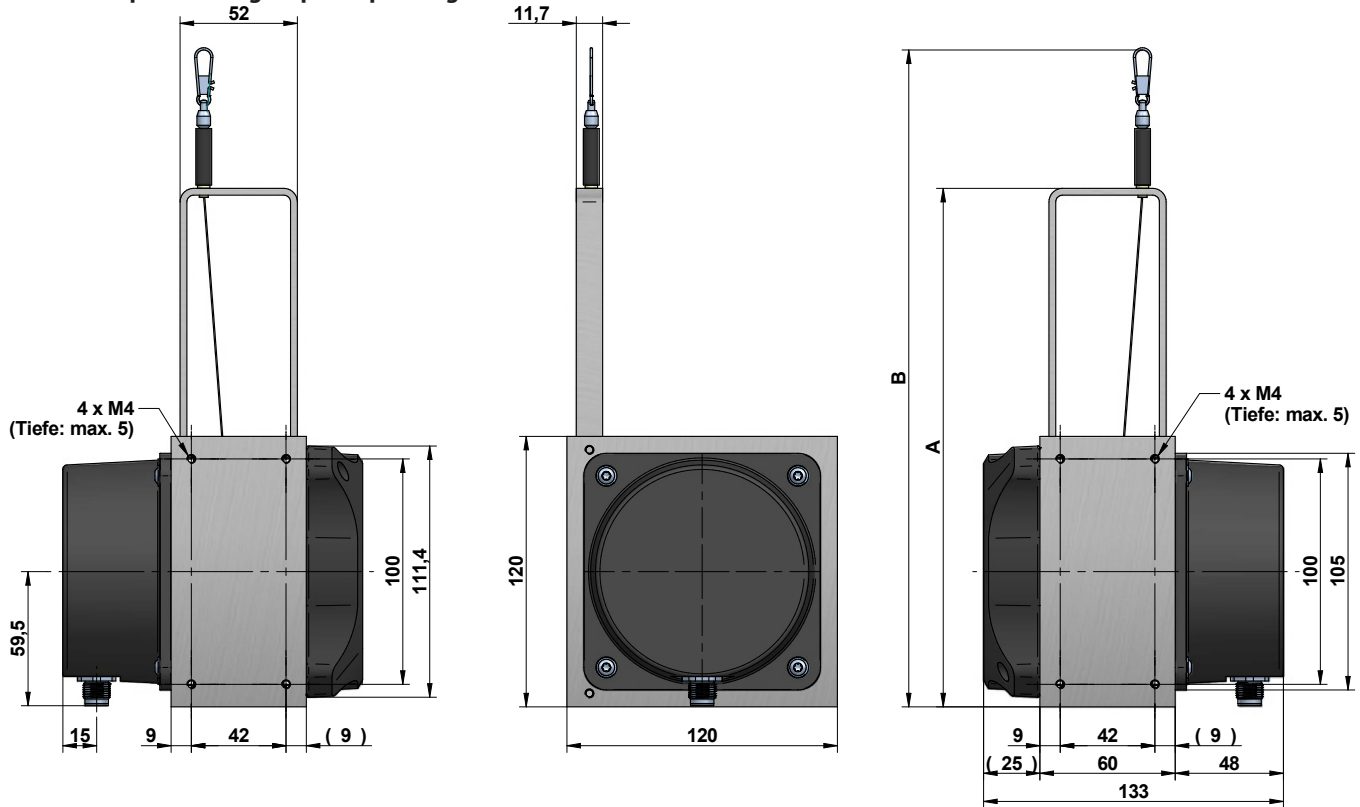

Dependency of dimensions A, B, C from the measurement range and the rope diameter

	Ø 0,5			Ø 1			Ø 1,5		
	A	B	C	A	B	C	A	B	C
3 m	230	~ 291.5	10.75	230	~ 291.5	10.75	230	~ 291.5	10.75
4 m	230	~ 291.5	10.75	230	~ 291.5	10.75	230	~ 291.5	10.75
5 m	230	~ 291.5	10.75	230	~ 291.5	10.75	320	~ 381.5	12.25
6 m	230	~ 291.5	10.75	320	~ 381.5	12.25	320	~ 381.5	12.25
7 m	230	~ 291.5	10.75	320	~ 381.5	12.25	-	-	-
8 m	230	~ 291.5	10.75	320	~ 381.5	12.25	-	-	-
9 m	230	~ 291.5	10.75	-	-	-	-	-	-
10 m	230	~ 291.5	10.75	-	-	-	-	-	-

Connector output / cable output all versions

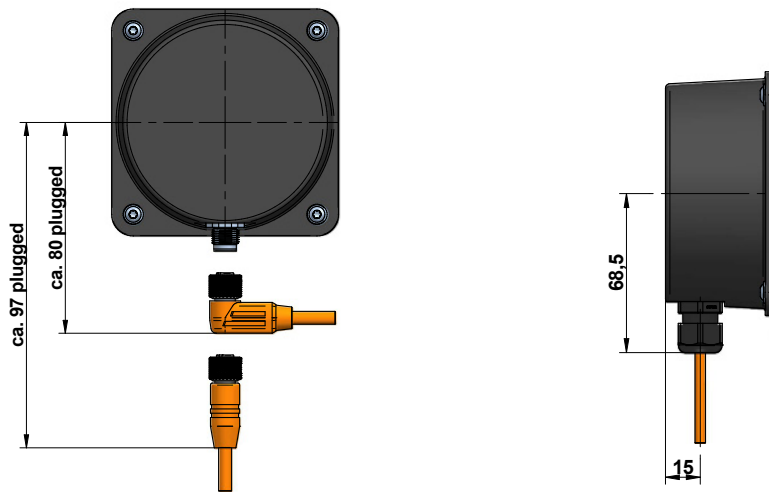

Note: when using close-range high pressure or high temperature spray downs for cleaning purposes the cable must be protected.

TECHNICAL DRAWING

Version C1: housing with perforated plate covering + open rope bridge

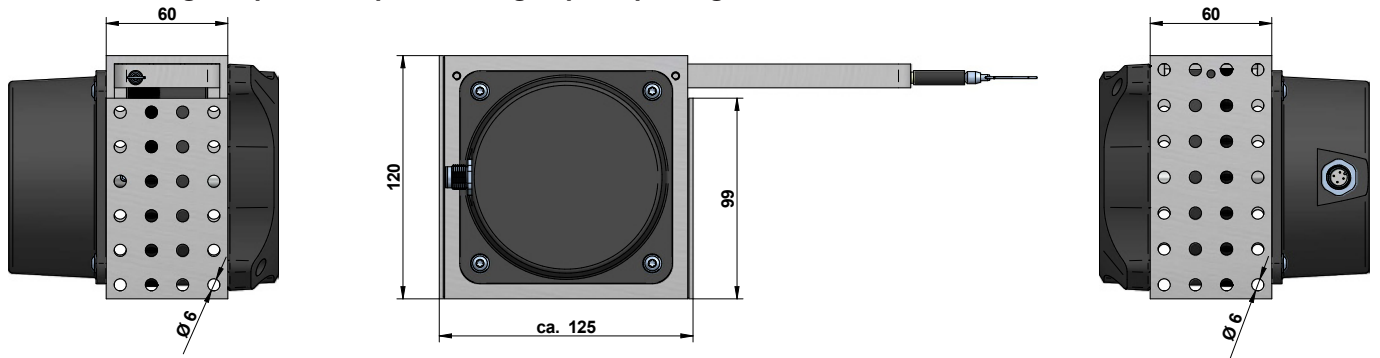

Version C2: housing with perforated plate covering + closed rope bridge

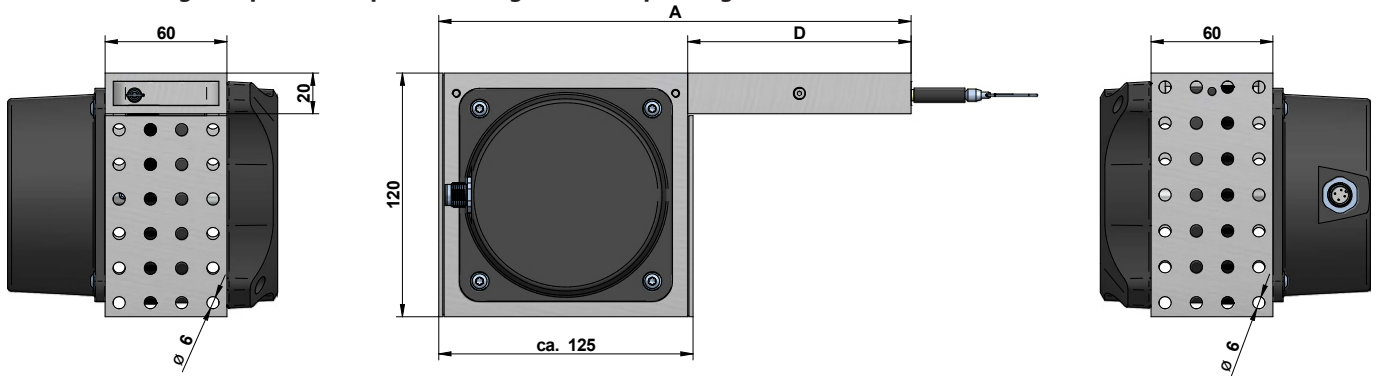

Version C3: closed housing + closed rope bridge

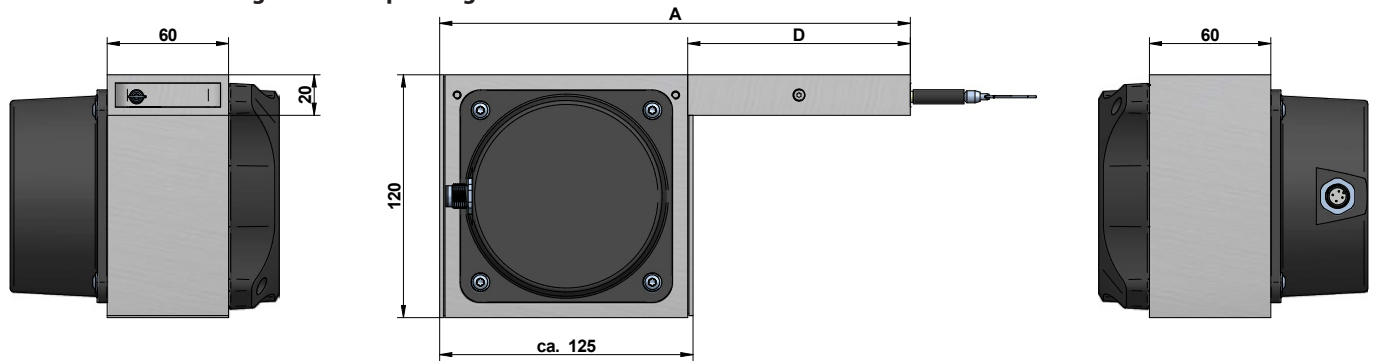

Dependency of dimensions A, B, C from the measurement range and the rope diameter

	Ø 0.5		Ø 1		Ø 1.5	
	A	D	A	D	A	D
3 m	233	110	233	110	233	110
4 m	233	110	233	110	233	110
5 m	233	110	233	110	323	200
6 m	233	110	323	200	323	200
7 m	233	110	323	200	-	-
8 m	233	110	323	200	-	-
9 m	233	110	-	-	-	-
10 m	233	110	-	-	-	-

OPTIONS

The following table gives an overview of frequently used options, with which the standard sensors can be equipped.

Option	Order code	Description
Changed cable or connector orientation	K1, K2, K3	Rope bridge points upwards: Standard: cable or connector output shows downwards K1: cable or connector output shows to the right K2: cable or connector output shows upwards K3: cable or connector output shows to the left
Improved linearity	L10, L25	Improved linearity 0.1 % (L10) or 0.25 % (L25)
Inverted output signal (only analog output)	IN	The analog signal of the sensor is increasing by extracting the rope (standard). Option IN inverts the signal, i.e. the signal of the sensor declines by extracting the rope.
Redundant output signal	R1, R2, R3, R4	By using a double potentiometer the sensor delivers two independent output signals. R1: 2 x 1 kΩ R2: 2 x 0...5 V or 2 x 0...10 V R3: 2 x 4...20 mA R4: 2 x CANopen
Sensor housing	C1, C2, C3	Standard: open housing + open rope bridge C1: housing with perforated plate covering + open rope bridge C2: housing with perforated plate covering + closed rope bridge C3: closed housing + closed rope bridge
Wire rope diameter	D05, D10, D15	The wire rope made of V4A stainless steel, 1.4401. Please choose the wire rope diameter in part two of the order code. D05: Ø 0.5 mm (standard) D10: Ø 1 mm (not available with measurement ranges 9 m and 10 m) D15: Ø 1.5 mm (not available with measurement ranges 7 m up to 10 m)
Rope fixation by M4 thread (not available with wire rope diameter 1.5 mm)	M4	Optional, pivoted rope fixation with screw thread M4, length 22 mm. Ideal for attachment to through holes or thread holes M4.
Rope fixation with cylindrical pin and M6 through bore	ZH, ZR	ZH: cylindrical pin with M6 through bore ZR: cylindrical pin with M6 through bore and carbine ring
Protection class IP69K	IP69	All relevant components are completely encapsulated. Suitable for close-range high pressure or high temperature spray downs. Only in combination with cable output.
Increased temperature range Low	T40	The use of special components allow a working temperature down to -40 °C (up to +85°C).

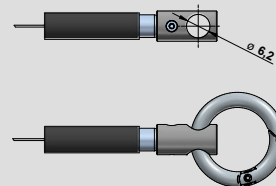
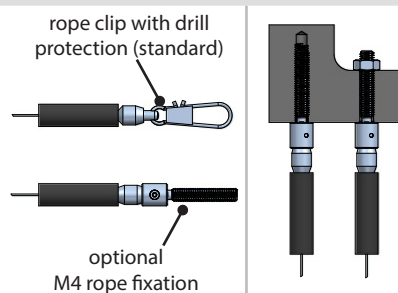
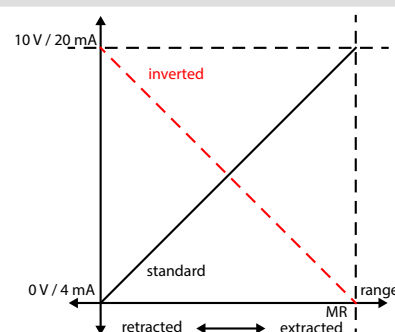
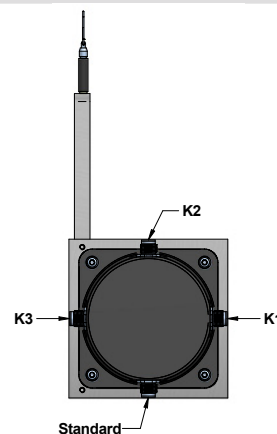

ACCESSORY SQUEEZER FOR TEACHABLE OUTPUTS 5VT AND 10VT

Draw wire sensors with the analogue output versions 5VT and 10VT are equipped with teachable, internal electronics, called VT-Electronics. The signals provided by the sensor's potentiometer are digitized by the VT-Electronics. This digital information is first processed by the electronics, then transformed back and given out as an analogue output signal 0 to 5 V or 0 to 10 V.

The digitization offers two possibilities of adjustment, by which the sensor can be configured individually using the Squeezer:

1. Teaching of the measurement range. After a successful teaching process, the squeezer can be pulled off the sensor and be replaced by a standard cable or connector.
2. Setting an individual switching point. The squeezer allows the setting of an individual switching point open collector. The switching signal is emitted through the multi-functional line MFL.

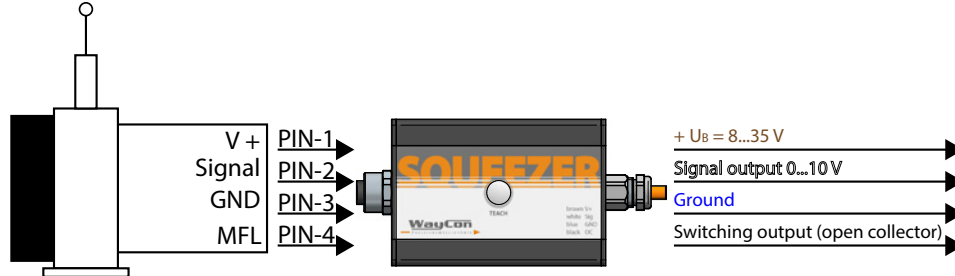

A detailed description of the functions can be found in a separate [manual](#).

Electrical connection Squeezer

Accessory:
Connection cable sensor to
Squeezer:
K4P1,5M-SB-M12

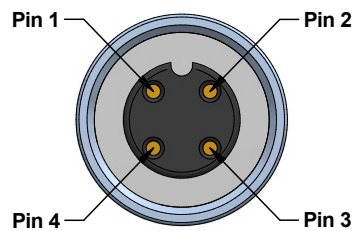

Connector (to sensor)		Cable ends (to PLC)	
PIN 1	V +	BN	V +
PIN 2	Signal	WH	Signal
PIN 3	GND	BU	GND
PIN 4	MFL*	BK	NPN*

MFL = multi-functional line
* The open collector is a NPN switching output

GENERAL ACCESSORIES

Deflection pulley - UR2

The rope must be extracted from the sensor vertically. The maximum variation from the vertical is 3°. A deflection pulley allows a change in the direction of the wire rope. Several pulleys may be used. The rope clip must not be guided over the deflection pulley.

- Material foot: anodised aluminium
 Material rope wheel: POM-C
 Mounting: by 2 hexagon socket or countersunk screws M6, vertical or horizontal mounting possible. Ball bearings: with special low temperature grease and RS-sealing.
 Temperature: -40...+80 °C.

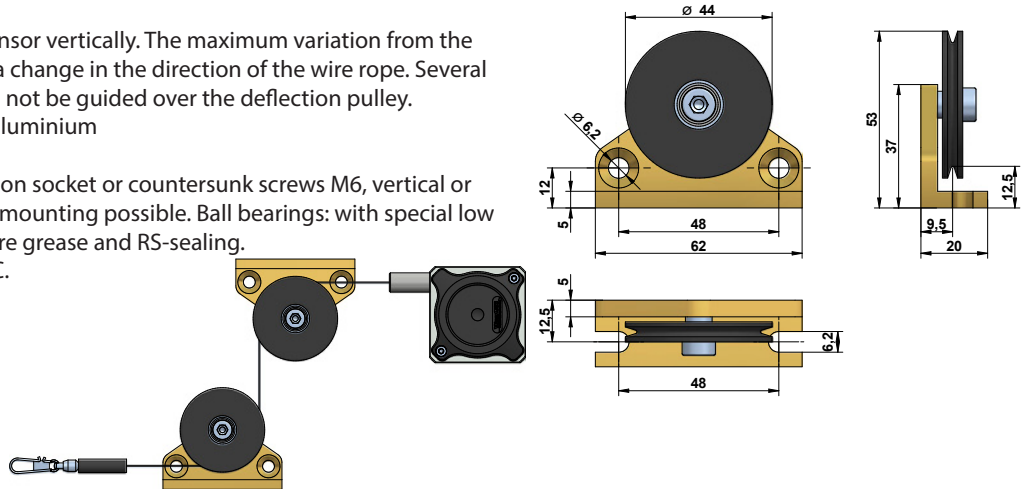

Rope extension - SV

For bridging a greater distance between the measuring target and the sensor a rope extension can be applied. The rope clip must not be guided over the deflection pulley.

Please specify the length needed in your order (XXXX). The minimum length is 150 mm:

- SV1-XXXX: rope extension (150...4995 mm)
- SV2-XXXX: rope extension (5000...19995 mm)
- SV3-XXXX: rope extension (20000...40000 mm)



Magnetic clamp - MGG1

Use the magnetic clamp to quickly attach the rope to metallic objects without any assembly time. A rubber coating provides gentle contact (e. g. on varnished surfaces) and prevents from slipping due to vibration. The magnet consists of a neodym core for an increased adhesive force of 260 N. The hook makes it easy to attach the rope clip.

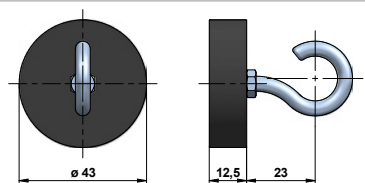

ACCESSORIES CABLES AND CONNECTORS

Single analog signal

Cable with connector M12, 4 poles, shielded

K4P2M-S-M12	2 m, connector straight
K4P5M-S-M12	5 m, connector straight
K4P10M-S-M12	10 m, connector straight
K4P2M-SW-M12	2 m, connector angular
K4P5M-SW-M12	5 m, connector angular
K4P10M-SW-M12	10 m, connector angular

PIN	1	2	3	4
Cable colour	BN	WH	BU	BK

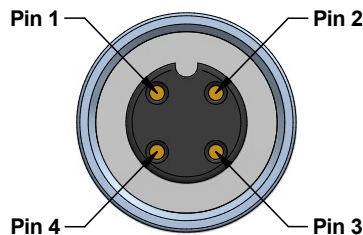

Mating connector M12, 4 poles, shielded, IP67

D4-G-M12-S	straight, M12 for self assembly
D4-W-M12-S	angular, M12 for self assembly
	cable passage: \varnothing 4...8 mm
	wire cross-section: 0.14...0.34 mm ²



Digital signal CANopen

Cable with connector M12, 5 poles, shielded

K5P2M-S-M12	2 m, connector straight IP67
K5P2M-SW-M12	2 m, connector angular, IP67

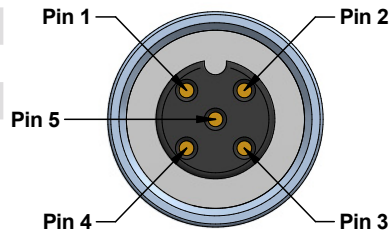

PIN	1	2	3	4	5
Cable colour	BN	WH	BU	BK	GY

Redundant analog signal and CANopen with offline configuration via Squeezer

Cable with connector M12, 8 poles, shielded

K8P2M-S-M12	2 m, connector straight
K8P5M-S-M12	5 m, connector straight
K8P10M-S-M12	10 m, connector straight
K8P2M-SW-M12	2 m, connector angular
K8P5M-SW-M12	5 m, connector angular
K8P10M-SW-M12	10 m, connector angular

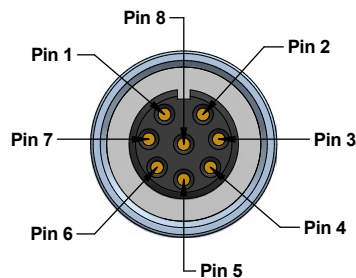

Mating connector M12, 8 poles, shielded, IP67

D8-G-M12-S	straight, M12 for self assembly
D8-W-M12-S	angular, M12 for self assembly
	cable passage: \varnothing 4...8 mm
	wire cross-section: 0.14...0.34 mm ²

PIN	1	2	3	4	5	6	7	8
Cable colour	WH	BN	GN	YE	GY	PK	BU	RD



INSTALLATION

- Mount the sensor at the designated place by using the fixing holes before extracting the rope and before attaching the rope to the measuring target.
- Open the rope clip after the sensor is fully mounted and extract the measuring rope. Hook the rope clip on the measuring object and close the bracket of the clip. For safety reasons put a screw driver trough the clip to extract the rope.
- Check the track of the measuring target on collision with the sensor housing and on exceeding the specified measurement range. When installing the sensor make sure that the rubber stopper does not touch the rope outlet.
- Connect the electronics according to the sensor type. When laying the cables be careful not to under-run the minimal allowed bending radius of the cable (5 x cable diameter).
- The rope must be extracted from the sensor vertically.** The maximum variation from the vertical is 3°. Avoid carefully extracting the rope at an inclination, since the durability of the instrument would shorten considerably. If it is not possible to keep the limit of 3°, a deflection pulley has to be used.
- The measuring range begins after approximately 2 mm extracted rope.
- When mounting outdoors protect the sensor and the rope from icing at temperatures below 0 °C.
- Guide the rope preferably in corners or guarded in channels to prevent pollution or accidental touch.
- When operating the sensor, take care **not to let the rope snap back** by mistake or extract the rope **over the specified measurement range**, as this might destroy the sensor.
- Maintenance: These instruments are maintenance-free. If however, the rope is soiled due to adverse environmental conditions, it can be cleaned with a cloth drenched in resin-free machine oil.

WARNING NOTICES

- Do not let the rope snap back. If the rope is retracted freely, this may lead to injuries (whiplash effect) and the device may be damaged.
- Caution when unhooking and retracting the rope into the sensor.
- Never exceed the specified measurement range when extracting the rope!
- Do not try to open the device. The stored energy of the spring drive may lead to injuries when being mishandled.
- Do not touch the rope when operating the sensor.
- Avoid guiding the rope over edges or corners. Use a deflection pulley instead.
- Do not operate the sensor if the rope is buckled or damaged. A ripping of the rope may lead to injuries or a damaging of the sensor.
- Only for standard version with open housing: the free turning of the rope drum **must** be ensured. In case the rope drum gets blocked there is a serious danger of injury and the sensor may get destroyed.

ORDER CODE

MH120 — □ — □ — □ — □ — □

Measurement range MR [m]	
3 / 4 / 5 / 6 / 7 / 8 / 9 / 10	

Wire rope	
Diameter 0,5 mm (Standard)	D05
Diameter 1 mm (not MR 9 and 10)	D10
Diameter 1,5 mm (not MR 7 to 10)	D15

Output signal		
Potentiometer	1 kΩ	1R
Voltage	0...5 V	5V
Voltage	0...10 V	10V
Voltage	0...5 V (teachable)	5VT
Voltage	0...10 V (teachable)	10VT
Current	4...20 mA	420A
Digital	CANopen	WCAN
Digital	CANopen offline configurable via Squeezer	WCANP

Connection	
Connector output M12 radial, 4 pole ¹	SR12
Cable output radial ²	KR_ _

	Version
-	Standard
0	Sensor with options

Option	Description (see page 8)
K1	cable or connector output to the right
K2	cable or connector output upwards
K3	cable or connector output to the left
L10	improved linearity 0.1 %
L25	improved linearity 0.25 %
IN	inverted output signal
R1	redundant output signal 1 R
R2	redundant output signal 5V, 10V
R3	redundant output signal 420A
R4	redundant output signal WCAN
C1	perforated plate covering + open rope bridge
C2	perforated plate covering + closed rope bridge
C3	closed housing + closed rope bridge
M4	rope fixation M4 (not with D15)
ZH	cylindrical pin
ZR	cylindrical pin with carbine ring
IP69	Protection IP69K, only cable output
T40	Temperature range -40...+85 °C

¹ 5 pole in combination with WCAN or option R4
8 pole in combination with WCANP or options R1, R2, R3

² only in combination with option IP69
Length in m (Minimum 2 m)
Examples: KR02 = 2 m, KR05 = 5 m

Note: If the option T40, L10, or L25 is chosen for a sensor with redundant signal (options R1, R2, R3, R4), the price for this option gets doubled.

GENERAL ACCESSORIES

SQUEEZER2M	accessory for VT or WCANP output, 2 m cable
SQUEEZER5M	accessory for VT or WCANP output, 5 m cable
SQUEEZER10M	acccy for VT or WCANP output, 10 m cable
UR2	deflection pulley

MGG1	magnetic clamp
SV1-XXXX	rope extension (150 mm up to 4995 mm)
SV2-XXXX	rope extension (5000 mm up to 19995 mm)
SV3-XXXX	rope extension (20000 mm up to 40000 mm)

ACCESSORIES CABLE AND CONNECTOR

Cable with mating connector M12, 4 poles, shielded

K4P2M-S-M12	2 m, straight connector
K4P5M-S-M12	5 m, straight connector
K4P10M-S-M12	10 m, straight connector
K4P2M-SW-M12	2 m, angular connector
K4P5M-SW-M12	5 m, angular connector
K4P10M-SW-M12	10 m, angular connector

Mating connector M12, 4 poles, shielded

D4-G-M12-S	straight, M12 for self assembly
D4-W-M12-S	angular, M12 for self assembly

Cable with mating connector M12, 5 poles, shielded

K5P2M-S-M12	2 m, straight connector
K5P2M-SW-M12	2 m, angular connector

Cable with mating connector M12, 8 poles, shielded

K8P2M-S-M12	2 m, straight connector
K8P5M-S-M12	5 m, straight connector
K8P10M-S-M12	10 m, straight connector
K8P2M-SW-M12	2 m, angular connector
K8P5M-SW-M12	5 m, angular connector
K8P10M-SW-M12	10 m, angular connector

Mating connector M12, 8 poles, shielded

D8-G-M12-S	straight, M12 for self assembly
D8-W-M12-S	angular, M12 for self assembly

Connection cable sensor to Squeezer

K4P1,5M-SB-M12	1.5 m, 4-pole, shielded
K48P03M-SB-M12	0.3 m, shielded, 8 poles to 4 poles *

Adapter cable WCANP to CAN-Bus

K58P03M-SB-M12	0.3 m, shielded, 8 poles to 5 poles
----------------	-------------------------------------

* for redundant analog signal and CANopen with offline configuration via Squeezer (WCANP)

ACCESSORY DISPLAY

Digital display 2 channels, 0...10 V / 4...20 mA

WAY-AX-S	Touchscreen, supply: 18...30 VDC
WAY-AX-S-AC	Touchscreen, supply: 115...230 VAC

More information about digital displays can be found [here](#).

Subject to change without prior notice.

WayCon Positionsmesstechnik GmbH
 email: info@waycon.de
 internet: www.waycon.biz

WayCon

Positionsmesstechnik

Head Office
 Mehlsbeerstr. 4
 82024 Taufkirchen
 Tel. +49 (0)89 67 97 13-0
 Fax +49 (0)89 67 97 13-250

Office Köln
 Auf der Pehle 1
 50321 Brühl
 Tel. +49 (0)2232 56 79 44
 Fax +49 (0)2232 56 79 45