

SE 110.12

Lines of influence on the Gerber beam



The illustration shows SE 110.12 in the frame SE 112.

Description

- articulated beam with two cantilever beams and a suspended beam as an example of a typical bridge
- direct indication of reactions
- lines of influence for different load cases

Many bridges are executed as Gerber beams. Bridges are subjected to moving loads. Consequently, it is important to take these moving loads into account in the design process. To that end, the so-called lines of influence are determined. Lines of influence describe static reactions to a moving load, such as the internal reactions of the beam or support reactions. The lines of influence are determined by way of method of sections and the conditions of equilibrium, in the same way as the bending moment diagram for a static load for example.

A Gerber beam is an articulated beam, in the case of SE 110.12 with two cantilever beams and a suspended beam between them. Two supports support each cantilever beam. The suspended beam is mounted on articulated supports on each of the cantilever beam arms. As a result the entire beam is statically determinate.

The cantilever beam supports are equipped with force gauges which indicate the support reactions.

Single loads and a moving load are provided to place load on the beam. This means the beam can be subjected to point or distributed loads, or to a moving load. The force gauges indicate the effect of a moving load directly in the support reactions. The supports are movable.

All the component elements of the experiment are clearly laid-out and housed securely in a storage system. The complete experimental setup is arranged in the frame SE 112.

Learning objectives/experiments

- familiarisation with a Gerber beam
- application of the method of sections and the conditions of equilibrium to calculate the support forces for
 - ▶ point load
 - ▶ distributed load
 - ▶ moving load
- determination of the internal reactions under static load
 - ▶ shear force curve
 - ▶ bending moment diagram
- determination of the lines of influence under moving load
- comparison of the calculated and measured reactions for static and moving load

SE 110.12

Lines of influence on the Gerber beam

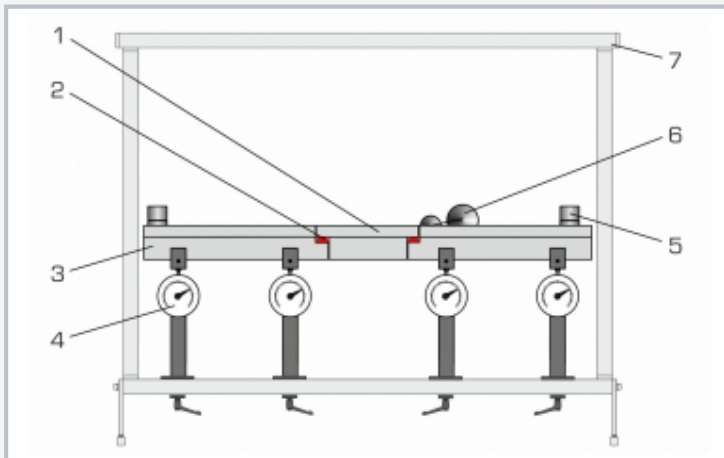

1 suspended beam, 2 articulated support, 3 cantilever beam, 4 support with force gauge, 5 weight, 6 moving load, 7 frame SE 112

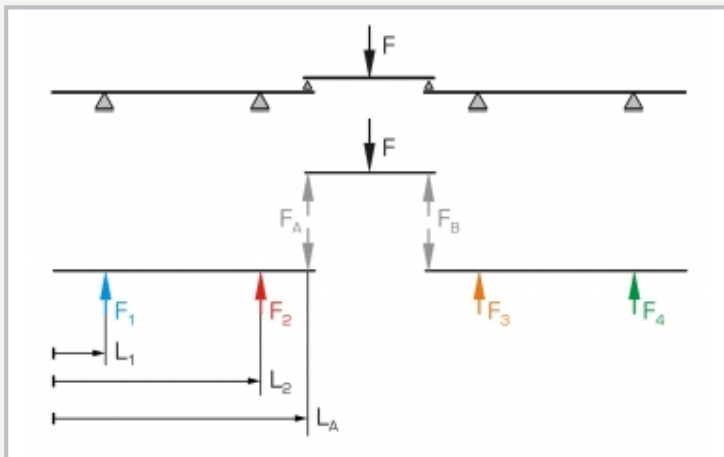

Top: simplified experimental setup (Gerber beam), bottom: free-body diagram: F applied force, $F_A + F_B$ reactions of the articulated supports, $F_1 \dots F_4$ reactions of the supports with force gauge, L_1, L_2, L_A positions of the supports

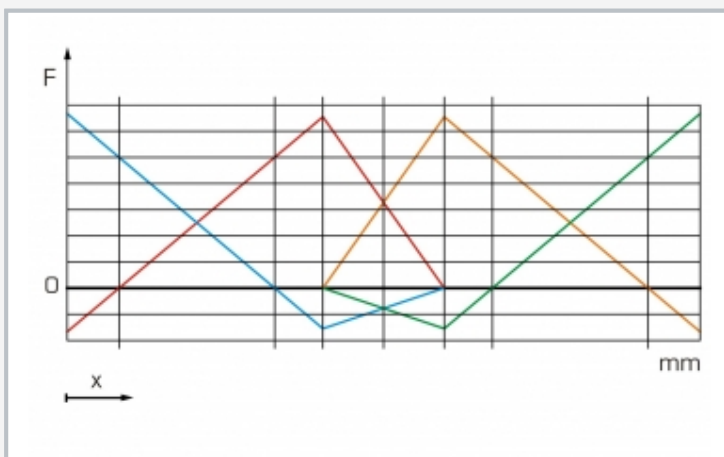

Lines of influence for a moving point load (see also free body diagram): blue: support 1, red: support 2, orange: support 3, green: support 4

Specification

- [1] investigation of the lines of influence in a statically determinate Gerber beam under different loading
- [2] Gerber beam comprising 2 cantilever beams and 1 suspended beam
- [3] suspended beam mounted by articulated supports on cantilever beams
- [4] beam subjected to moving load or loaded down by single loads
- [5] 4 movable supports with force gauge
- [6] storage system to house the components
- [7] experimental setup in frame SE 112

Technical data

Beam

- total length: 1220mm
- cantilever beam length: 503mm
- suspended beam length: 250mm

Force gauge: $\pm 50\text{N}$

Weights

- 24x 5N
- 12x 1N
- moving load: 10+20N

LxWxH: 1170x480x178mm (storage system)

Weight: approx. 40kg (total)

Scope of delivery

- 1 Gerber beam (2 cantilever beams + 1 suspended beam)
- 4 supports with force gauge
- 1 moving load
- 1 set of weights
- 1 storage system with foam inlay
- 1 set of instructional material

SE 110.12

Lines of influence on the Gerber beam

Required accessories

022.11200

SE 112

Mounting frame